

A = PAD HEIGHT  
 B = BOTTOM OF PAD ABOVE FLOOR  
 C = BEAM DEPTH AT TOP OF PAD  
 D = BEAM DEPTH AT BOTTOM OF PAD  
 E = BEAM FLANGE WIDTH

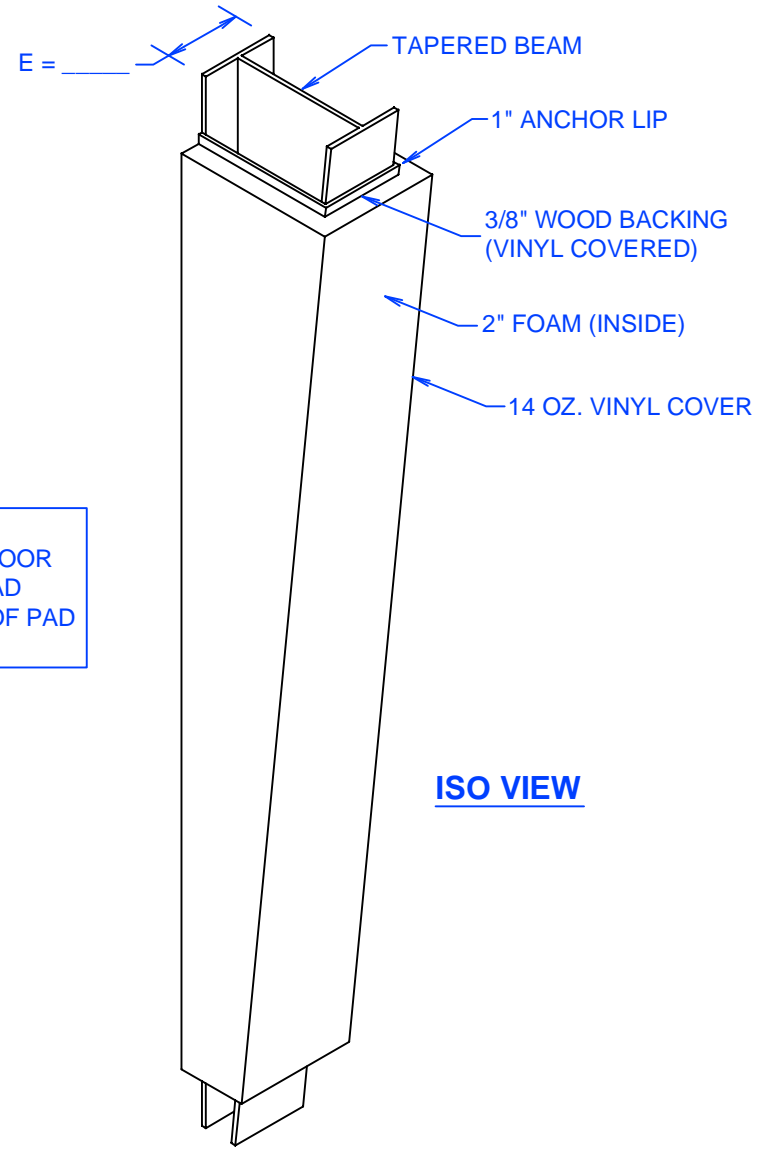

**SIDE VIEW**

**ISO VIEW**

REVISION / STAGE:	MONTH / DAY / YEAR	RELATED DRAWINGS / INFORMATION:
WP-TCOL		THIS DRAWING IS PROPERTY OF ARIZONA COURTLINES, INC. AND MAY NOT BE REPRODUCED WITHOUT WRITTEN PERMISSION

WP-TCOL-6    WP-TCOL-7    WP-TCOL-8

**TAPERED COLUMN PAD**  
 HEIGHT:    6'-0"    7'-0"    8'-0"

**ARIZONA COURTLINES, INC.**  
  
 8742 NORTH 78TH AVENUE  
 PEORIA, ARIZONA 85345  
 TEL. 623.939.8126  
 FAX. 623.939.2526  
 www.ARIZONACOURTLINES.com

DRAWN BY: <b>EDDIE CAFFERAT</b>
CHECKED BY:
QUANTITY: